

COBRA NC 0400 B

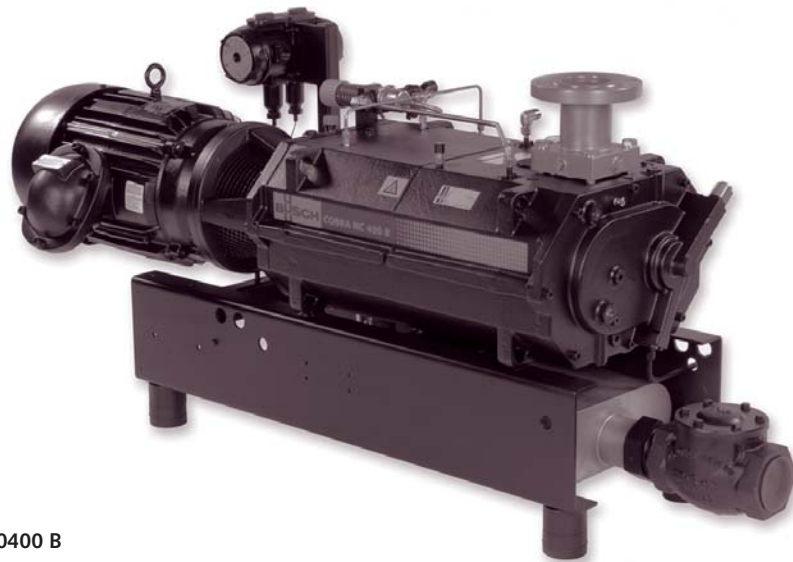

COBRA NC 0400 B

Description

The COBRA NC single stage, direct driven rotary screw dry vacuum pumps are designed for difficult applications in the pharmaceutical and chemical processing industries.

The COBRA NC series, B version vacuum pumps incorporate a unique, monoblock, continuously variable pitch screw design. The variable pitch design operates more efficiently, has a higher CFM to horsepower ratio, and lower operating temperatures than traditional dry screw vacuum pumps.

The COBRA NC 0400 B provides vacuum down to .0075 torr, and pumping speeds up to 247 ACFM. They will operate at any pressure from atmospheric down to ultimate pressure. For higher pumping speeds and lower ultimate pressures, Busch offers COBRA/booster systems along with many other custom designed vacuum systems.

Standard Equipment

- NEMA C-face motor, explosion proof Class I, Groups C&D, Division 1, Service factor 1.15
- Cooling water flow control system
- Cooling water temperature switch and gauge
- Exhaust gas temperature switch
- Exhaust check valve
- Molybdenum disulfide compound coating on all internal parts
- Oil lubricated, mechanical shaft seals on inlet shaft ends
- Oil lubricated, mechanical shaft seals with piston ring labyrinth seals on discharge shaft ends
- Purge regulator for discharge end labyrinth seals
- Stainless steel exhaust silencer
- Stainless steel inlet flange

Dry Screw Vacuum Pumps

Operating Principle

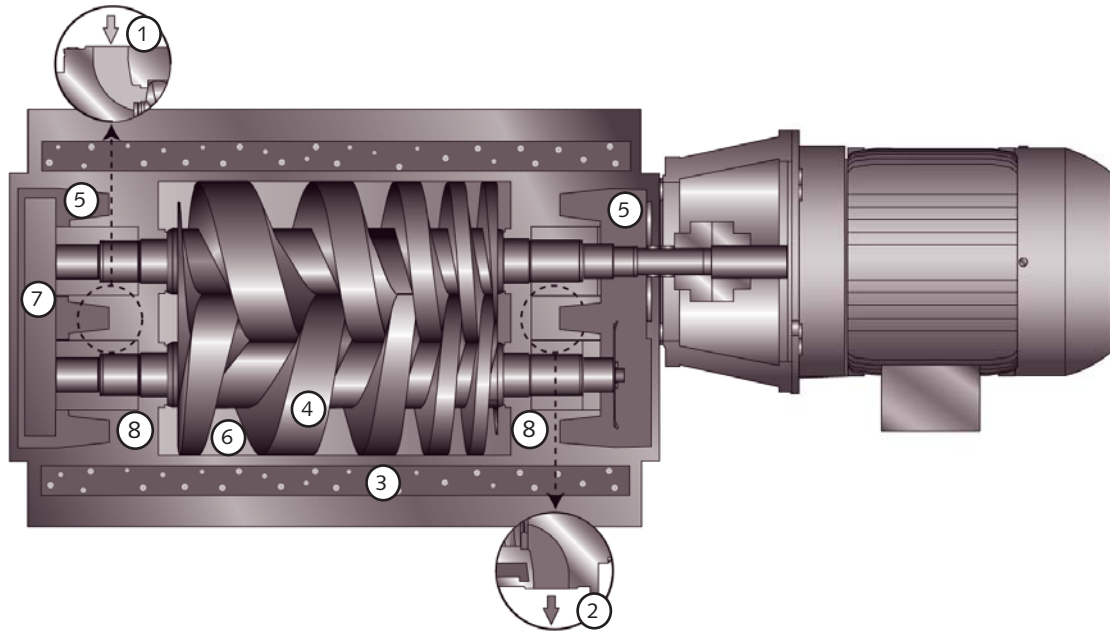

- | | |
|----------------|------------------|
| 1 Inlet | 5 Oil |
| 2 Exhaust | 6 Gas Path |
| 3 Water Jacket | 7 Timing Gears |
| 4 Screw | 8 Bearings/Seals |

Operating Principle

Two counter rotating screw shaped rotors rotate inside of a common cylinder. As the screws rotate, they trap a volume of gas at the inlet of the vacuum pump, and convey that gas towards the vacuum pump discharge.

The variable pitch design causes an internal compression within the pumping chamber prior to discharging the gas. This principle creates up to 50% higher efficiency (CFM per horsepower), and reduces the temperature rise by up to 50% in comparison with traditional screw designs.

The screws do not contact each other or the cylinder/end plates due to precision manufacturing and gears that maintain rotor timing. Therefore, no lubricant is required in the pumping chamber.

Lubricants for the bearings and gears are sealed from the pumping chamber by mechanical shaft seals.

Cooling is achieved by a direct (once-through) water cooling system which utilizes an integral coolant pump and flow controlling valve.

Applications

- Drying processes in the pharmaceutical industry demanding special product purity
- Recovery of solvents, from drying, filtration, crystallization, and distillation processes
- Degassing processes in the furnace, metal and coating industry
- Degassing processes in the food industry
- Impregnation processes
- Crystal growing for semiconductor and solar industries
- Extruder degassing
- Recycling of process gases without adding contamination
- Industrial furnaces
- Evacuation of gas bottles prior to filling with high-purity gases
- Leak testing
- Central vacuum for laboratory and pilot plants
- Sinter processes
- Coating technology
- Vacuum processes in all applications where oil-free vacuum is required



Pumping Speed vs. Inlet Pressure
NC 0400 B

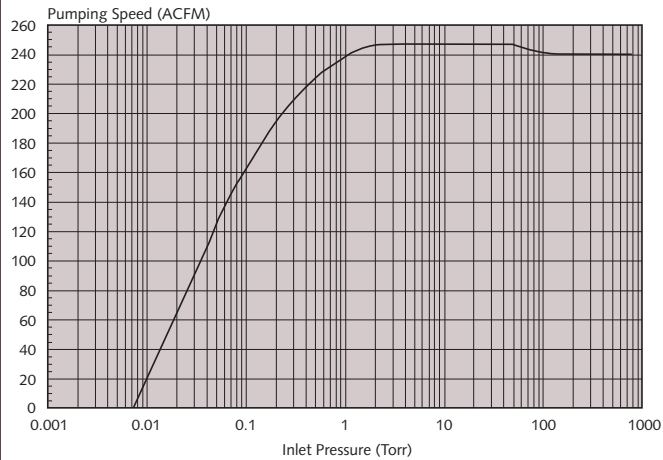

Brake Horsepower vs. Inlet Pressure
NC 0400 B

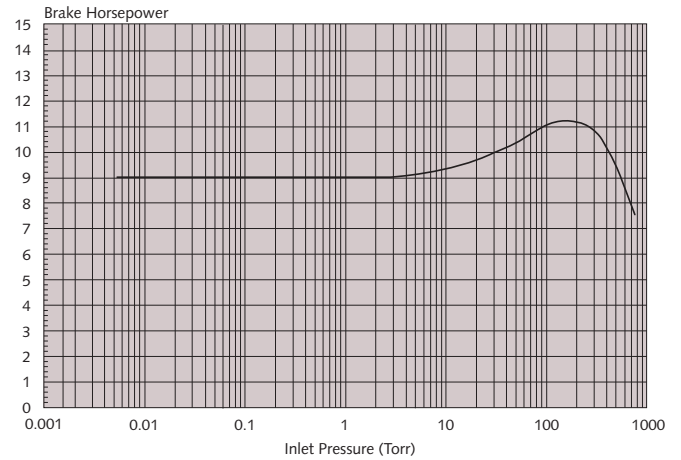

Technical Data		NC 0400 B
Nominal pumping speed	ACFM	247
Ultimate pressure	Torr	.0075
Motor size	HP	15
Motor rotational speed	RPM	3600
Sound level rating*	dbA	69
Approximate oil sump capacity	Qts.	1
Average water usage rate	GPM	1.3
Approximate weight (as shown)	Lbs	1433

All performance data is based on ambient conditions of 14.7 PSIA and 70° F, and has a tolerance of +/- 10%.
*DIN EN ISO 2151

Dimensions

COBRA NC 0400 B

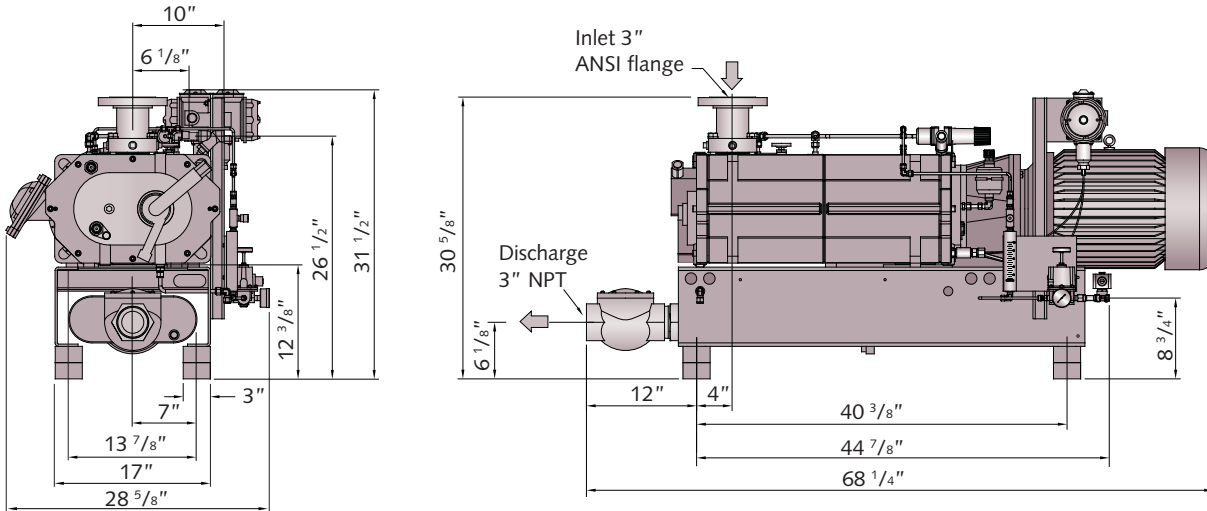

All dimensions in inches unless otherwise noted.

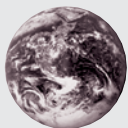

Busch - all over the world in industry

ISO 9001-2000 Registered Company

Busch, Inc. 516 Viking Drive Virginia Beach, VA 23452
Phone (757) 463-7800 FAX (757) 463-7407

www.buschpump.com
1-800-USA-PUMP

Amsterdam Barcelona Birmingham Basel Brussels Dublin Göteborg Helsinki Istanbul Copenhagen Kuala Lumpur Milan Maulburg Melbourne Montreal Moscow
 New York New Plymouth Oslo Paris San Jose São Paulo Seoul Singapore Taipei Tokyo Vienna